

Mechanics of Materials Qualifying Exam Study Material

The candidate is expected to have a thorough understanding of mechanics of materials topics. These topics are listed below for clarification. Not all instructors cover exactly the same material during a course, thus it is important for the candidate to closely examine the subject areas listed below. The textbook listed below is a good source for the review and study of a majority of the listed topics. One final note, the example problems made available to the candidates are from past exams and do not cover all subject material. These problems are not to be used as the only source of study material. The topics listed below should be your guide for what you are responsible for knowing.

Suggested textbook:

Fundamentals of Machine Elements, Hamrock, (McGraw-Hill)

Topic areas:

Study Chapter 2 – Chapter 5

Qualifying Exam: Solid Mechanics, Fall 2014

Problem 1.

A long thin steel plate of thickness t , width $2h$, and length $2a$ is subjected to, loads that produce the uniform stresses σ_0 at the ends. The edges at $y = \pm h$ are placed between the two rigid walls. Find displacement field in the plates if Young's modulus and Poisson's ratio of the plate are E and ν .

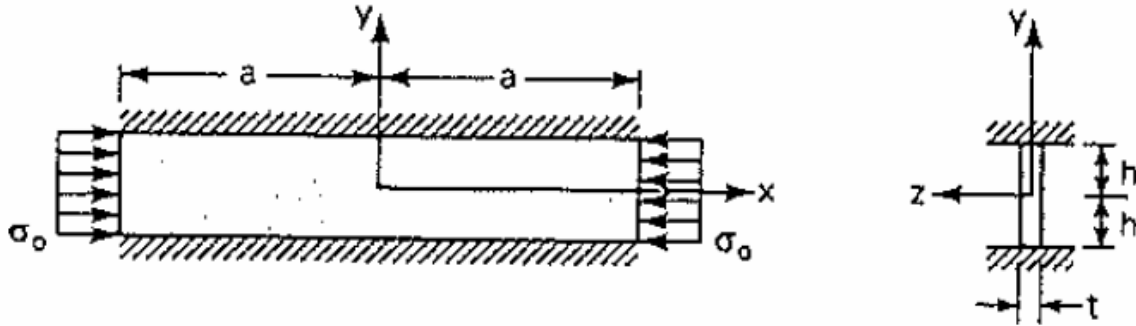

Problem 2.

An isotropic elastic sphere ($E = 207GPa$, $\mu = 79.2GPa$) of 5 cm radius is under the uniform

stress field $\sigma = \begin{bmatrix} 6 & 2 & 0 \\ 2 & -3 & 0 \\ 0 & 0 & 0 \end{bmatrix} MPa$. Find the change of volume for the sphere.

Problem 3.

In Cartesian coordinate systems, the tensor strain transformation equation is as follows.

$$e'_{pq} = l_{pi} l_{qj} e_{ij}$$

for

$$i, j, p, q = 1, 2, 3$$

Assume that all the strain components of the strain tensor in a material with reference to the Cartesian coordinate system $x_1x_2x_3$ are known. Using the transformation equation given above, determine the strain component e'_{11} .

The Cartesian coordinate system $x'_1x'_2x'_3$ is formed by rotating the coordinate system $x_1x_2x_3$ about the x_3 axis 30° counterclockwise as shown below.

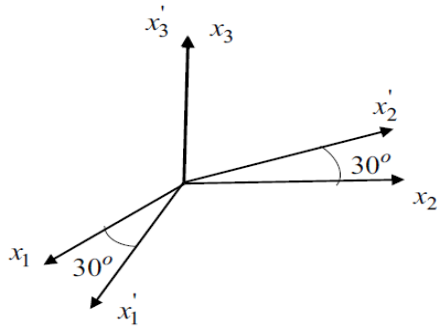

Problem 4.

A square reinforced-concrete pier 0.3×0.3 m in cross section and 1.2 m high is located as shown in the figure. The concrete is strengthened by the addition of eight vertical 25×25 mm square steel reinforcing bars placed symmetrically about the vertical axis of the pier. Find the stress in the steel and concrete and the deflection. ($E=17$ GN/m² for concrete and $E=205$ GN/m² for steel).

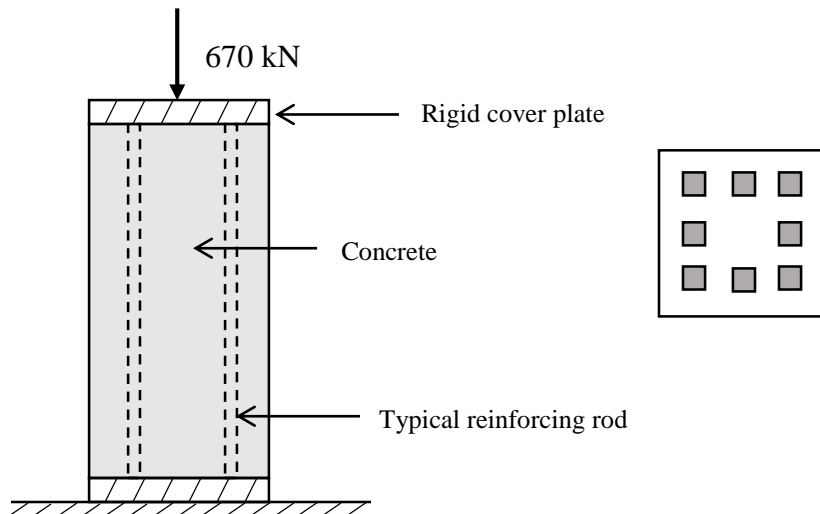

Name:

PhD Qualifying Exam: Solid Mechanics

Spring 2014

Problem 1.

Two-dimensional deformation at a certain point M is characterized by the following measurements:

- line element inclined to x_1 at 15° had length 5 mm before the deformation and 5.05 mm after;
- line element inclined to x_1 at 45° had length 10 mm before the deformation and 9.1 mm after;
- line element inclined to x_1 at 75° had length 4 mm before the deformation and 4.1 mm after;

Find:

- a) principal directions of deformation and principal elongations;
- b) dilatation at point M .

Problem 2.

A hollow ($R_{internal} = b$, $R_{external} = c$) and a solid ($R = a$) cylindrical shaft are constructed of the same material. The shafts are of identical length and cross-sectional area and both are subjected to pure torsion. Determine the ratio of the largest torques that may be applied to the shafts for $c = 1.4b$

- (a) if the allowable stress is τ_a
- (b) if the allowable angle of twist is θ_a .

Problem 3.

For the cantilever beam below, assume that the deflection of the centroidal axis (x - axis) is

$$v_c = a_0 + a_1x + a_2x^2 + a_3x^3$$

What is the strain energy of the beam? Using the Rayleigh-Ritz technique determine the equation that will be obtained when equating the coefficients of da_2 .

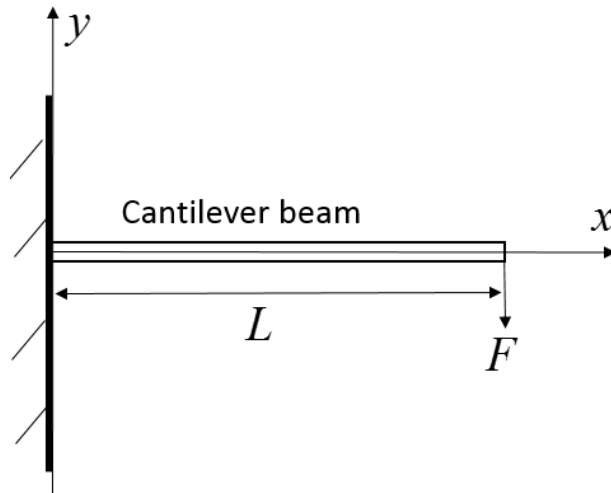

Problem 4.

Consider the beam with simple transverse supports at A and B and loaded with a uniformly distributed load $q = -w$ over a portion of the length. (a) Using the singularity functions, determine shear-force $V(x)$ and bending moment $M(x)$. (b) Plot the shear-force and bending moment diagrams.

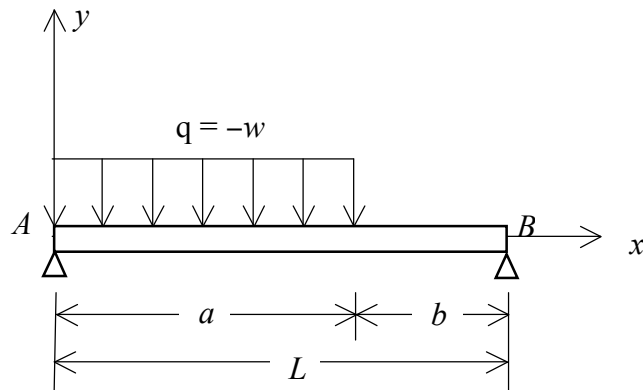

Name _____

Spring 2010

Qualifying Exam: Solid Mechanics

CLOSED BOOK

This portion of the qualifying exam is closed book. You may have a calculator.

Work 3 of the 4 problems. Be very clear which 3 you want graded (see below). It is not acceptable to work all 4 problems and hope that the graders pick out the best worked three.

I want problems #____, #____, and #____ graded.

Be sure to put your name on all papers handed in, including this cover sheet.

Qualifying Exam: Solid Mechanics**CLOSED BOOK****Reference Formulas**

The law for tensors transformation:

If two coordinate systems $x'y'z'$ and xyz are related by the direction cosines: $l_1 = \cos(x', x)$; $m_1 = \cos(x', y)$ etc as shown in the Table 1 below, then one can write the following equations for transformations of components of the symmetric second rank tensor:

$$a_{x'x'} = a_{xx}l_1^2 + a_{yy}m_1^2 + a_{zz}n_1^2 + 2(a_{xy}l_1m_1 + a_{yz}m_1n_1 + a_{xz}l_1n_1)$$

$$a_{y'y'} = a_{xx}l_2^2 + a_{yy}m_2^2 + a_{zz}n_2^2 + 2(a_{xy}l_2m_2 + a_{yz}m_2n_2 + a_{xz}l_2n_2)$$

$$a_{z'z'} = a_{xx}l_3^2 + a_{yy}m_3^2 + a_{zz}n_3^2 + 2(a_{xy}l_3m_3 + a_{yz}m_3n_3 + a_{xz}l_3n_3)$$

$$a_{x'y'} = a_{xx}l_1l_2 + a_{yy}m_1m_2 + a_{zz}n_1n_2 + a_{xy}(l_1m_2 + m_1l_2) + a_{yz}(m_1n_2 + n_1m_2) + a_{xz}(l_1n_2 + n_1l_2)$$

$$a_{x'z'} = a_{xx}l_1l_3 + a_{yy}m_1m_3 + a_{zz}n_1n_3 + a_{xy}(l_1m_3 + m_1l_3) + a_{yz}(m_1n_3 + n_1m_3) + a_{xz}(l_1n_3 + n_1l_3)$$

$$a_{y'z'} = a_{xx}l_2l_3 + a_{yy}m_2m_3 + a_{zz}n_2n_3 + a_{xy}(l_2m_3 + m_2l_3) + a_{yz}(m_2n_3 + n_2m_3) + a_{xz}(l_2n_3 + n_2l_3)$$

Table 1 Matrix of direction cosines

	x	y	z
x'	l_1	m_1	n_1
y'	l_2	m_2	n_2
z'	l_3	m_3	n_3

In 2-D case, normal and shear tractions (σ and τ) are related to components of stress tensor as follows:

$$\sigma = \sigma_x \cos^2 \theta + \sigma_y \sin^2 \theta + 2\tau_{xy} \sin \theta \cos \theta$$

$$\tau = \tau_{xy} (\cos^2 \theta - \sin^2 \theta) + (\sigma_x - \sigma_y) \sin \theta \cos \theta$$

The impact factor, the ratio of the maximum dynamic deflection, δ_{max} , to the static deflection, δ_{st} , is

$$\frac{\delta_{max}}{\delta_{st}} = 1 + \sqrt{1 + \frac{2h}{\delta_{st}}}, \text{ where } h \text{ is height from which the weight is dropped.}$$

Qualifying Exam: Solid Mechanics

CLOSED BOOK

1. A solid shaft of circular cross-section with radius 10 mm is subjected to an axial load $P=50.0 \text{ kN}$ and torsion T . For a maximum permissible shearing stress $\tau = 330 \text{ MPa}$ calculate the allowable torque T .
2. When a bolted connection fails, the threads may fail in either shear or tension. Estimate the number of threads (i.e., turns of the nut) that must be engaged in order to make either failure mode equally likely. Assume that the load is distributed evenly between the threads and that the bolt and nut are made from identical steel. *List your assumptions* and indicate the two possible failure modes with a sketch. Use .5 inch standard thread as an example. American Standard Thread Dimensions are shown.

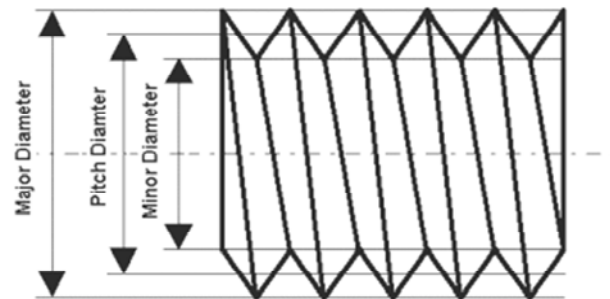
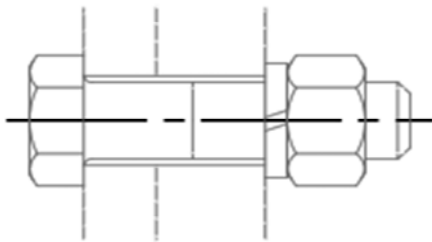

American Standard Thread Dimensions

Major Diameter (in)	Threads per inch	Thread Pitch (in)	Pitch Diameter (in)	Minor Diameter (in)
0.250	16	0.063	0.219	0.188
0.313	14	0.071	0.277	0.241
0.375	12	0.083	0.333	0.292
0.438	12	0.083	0.396	0.354
0.500	10	0.100	0.450	0.400
0.625	8	0.125	0.563	0.500
0.750	6	0.167	0.667	0.583
0.875	6	0.167	0.792	0.708
1.000	5	0.200	0.900	0.800

Qualifying Exam: Solid Mechanics

CLOSED BOOK

3. A large thin plate containing a small circular hole of radius a is subjected to biaxial loading as shown in the figure. Determine the stress concentration factor.

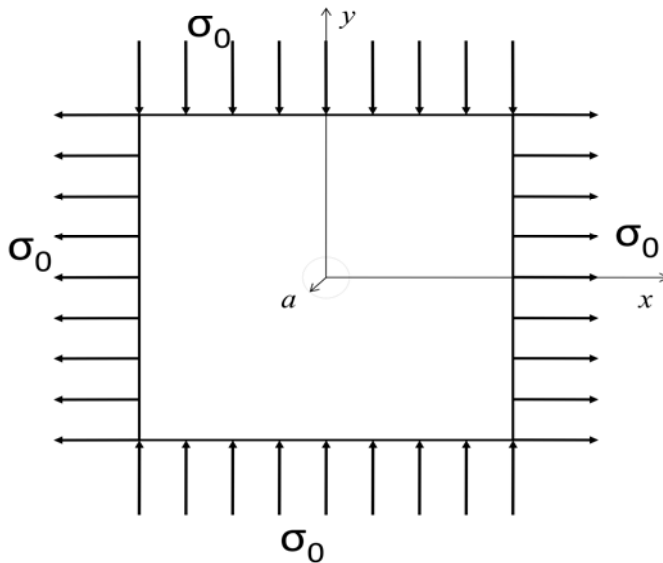

4. The steering system of a vehicle consists of a steering wheel, of a steering column which is a shaft of $\frac{3}{4}$ -in. diameter, and of a linkage which gives a 20:1 reduction in angular rotation between the steering wheel and the tires. Each of the front wheels carries 1,000 lb. of the weight, and the tires are inflated to a pressure of 30 psi. If the coefficient of friction between rubber and the ground is 0.6, calculate the maximum stress set up in the steering column while the wheels are being turned. (To keep the calculation simple, assume that the contacting region between tire and ground is a circle of 6.5-in. diameter, and that the pressure over it is uniformly 30 psi.)

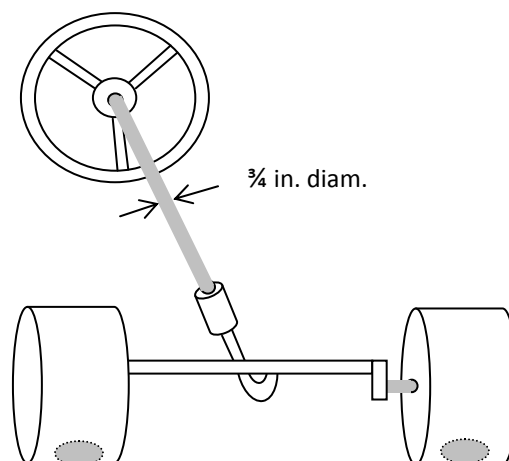

Qualifying Exam: Solid Mechanics

CLOSED BOOK

1. The built-up beam illustrated is clamped together with $\frac{1}{4}$ -in. bolts with a spacing s as shown. If each bolt can safely resist a shear force across it of 400 lbf , what is the bolt spacing required when the shear force V is $10,000 \text{ lbf}$?

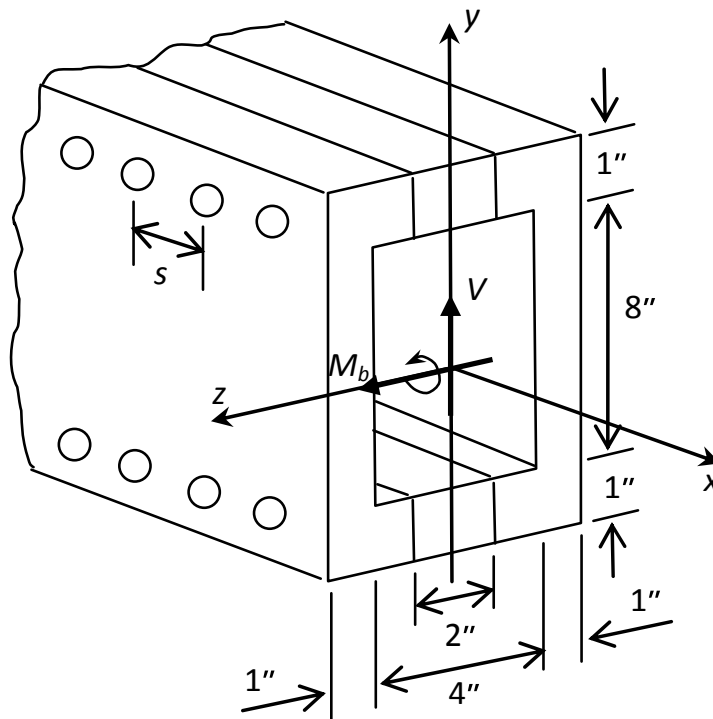

Qualifying Exam: Solid Mechanics

CLOSED BOOK

2. A 0° - 45° - 90° rosette is attached to a piece of isotropic and homogeneous material according to the recommendation of the rosette manufacturer as shown below. This material has a Poisson ratio of ν which is **NOT** equal to 0.285 . Strain gage A is aligned with the x_1 -axis, while strain gage C is aligned with the x_2 -axis and gage B is at 45° to the x_1 and x_2 axes. The strain gage factor of gages A, B and C are S_{gA} , S_{gB} and S_{gC} respectively. Also, the transverse sensitivity ratio of gages A, B and C are K_{tA} , K_{tB} and K_{tC} respectively. The strain gage factors and the transverse sensitivity ratios were determined using an isotropic and homogeneous material with a Poisson ratio of 0.285 . At a particular state of loading of the piece of material shown in the diagram below, the strains indicated by gages A, B and C were e_{Ai} , e_{Bi} and e_{Ci} .
- What are the indicated normal strains of the material in the x_1 and x_2 directions?
 - What is the corresponding indicated engineering shear strain γ_{12i} ?
 - Determine the corrected normal strains of the material in the x_1 and x_2 directions.

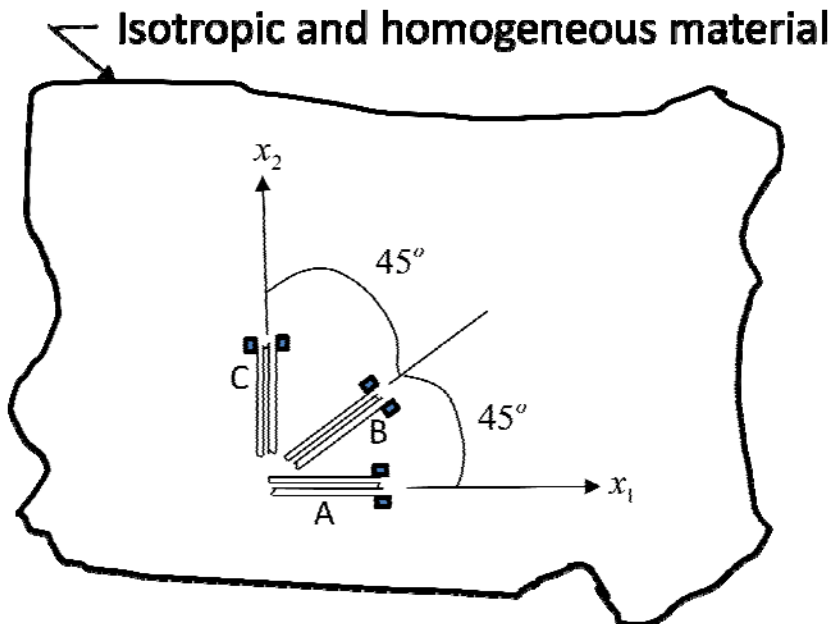

Qualifying Exam: Solid Mechanics**CLOSED BOOK**

3. At point P , the matrix of components of stress tensor (with respect to axes x_1, x_2, x_3) is as follows:

$$[\sigma_{ij}] = \begin{bmatrix} 20 & 10 & -10 \\ 10 & 30 & 0 \\ -10 & 0 & 50 \end{bmatrix} MPa$$

Determine:

- traction vector on a plane passing through this point and parallel to the plane $2x + y - 3z = 12$;
 - normal and shear tractions on the plane.
4. With reference to a rectangular Cartesian coordinate system, the state of strain at a point is given by the matrix

$$[\varepsilon] = \begin{bmatrix} 5 & 3 & 0 \\ 3 & 4 & -1 \\ 0 & -1 & 2 \end{bmatrix} \times 10^{-4}$$

What is the change of the angle between two initially perpendicular lines in the directions of $3e_1 + 2e_2 - 2e_3$ and $2e_1 + 3e_3$ emanating from the point?

Name _____

Spring 2008

Qualifying Exam: Mechanics of Materials

CLOSED BOOK

This portion of theThis portion of the qualifying exam is **closed** book. You may have a calculator.

Work 3 of the 4 problems. Be very clear which 3 you want graded (see below). It is not acceptable to work all 4 problems and hope that the graders pick out the best worked three.

I want problems #____, #____, and #____ graded.

Be sure to put your name on all papers handed in, including this cover sheet.

Qualifying Exam: Mechanics of Materials

CLOSED BOOK

Reference Equations

The law for tensors transformation:

If two coordinate systems $x'y'z'$ and xyz are related by the direction cosines: $l_1 = \cos(x', x)$; $m_1 = \cos(x', y)$ etc as shown in the Table 1 below, then one can write the following equations for transformations of components of the symmetric second rank tensor:

$$\begin{aligned}
 a_{x'x'} &= a_{xx}l_1^2 + a_{yy}m_1^2 + a_{zz}n_1^2 + 2(a_{xy}l_1m_1 + a_{yz}m_1n_1 + a_{xz}l_1n_1) \\
 a_{y'y'} &= a_{xx}l_2^2 + a_{yy}m_2^2 + a_{zz}n_2^2 + 2(a_{xy}l_2m_2 + a_{yz}m_2n_2 + a_{xz}l_2n_2) \\
 a_{z'z'} &= a_{xx}l_3^2 + a_{yy}m_3^2 + a_{zz}n_3^2 + 2(a_{xy}l_3m_3 + a_{yz}m_3n_3 + a_{xz}l_3n_3) \\
 a_{x'y'} &= a_{xx}l_1l_2 + a_{yy}m_1m_2 + a_{zz}n_1n_2 \\
 &\quad + a_{xy}(l_1m_2 + m_1l_2) + a_{yz}(m_1n_2 + n_1m_2) + a_{xz}(l_1n_2 + n_1l_2) \\
 a_{x'z'} &= a_{xx}l_1l_3 + a_{yy}m_1m_3 + a_{zz}n_1n_3 \\
 &\quad + a_{xy}(l_1m_3 + m_1l_3) + a_{yz}(m_1n_3 + n_1m_3) + a_{xz}(l_1n_3 + n_1l_3) \\
 a_{y'z'} &= a_{xx}l_2l_3 + a_{yy}m_2m_3 + a_{zz}n_2n_3 \\
 &\quad + a_{xy}(l_2m_3 + m_2l_3) + a_{yz}(m_2n_3 + n_2m_3) + a_{xz}(l_2n_3 + n_2l_3)
 \end{aligned}$$

Table 1 Matrix of Direction Cosines

	x	y	z
x'	l_1	m_1	n_1
y'	l_2	m_2	n_2
z'	l_3	m_3	n_3

In the 2-D case, normal and shear tractions (σ and τ) are related to components of stress tensor as follows:

$$\begin{aligned}
 \sigma &= \sigma_x \cos^2 \theta + \sigma_y \sin^2 \theta + 2\tau_{xy} \sin \theta \cos \theta \\
 \tau &= \tau_{xy} (\cos^2 \theta - \sin^2 \theta) + (\sigma_x - \sigma_y) \sin \theta \cos \theta
 \end{aligned}$$

The impact factor, the ratio of the maximum dynamic deflection, δ_{max} , to the static deflection, δ_{st} , is

$$\frac{\delta_{max}}{\delta_{st}} = 1 + \sqrt{1 + \frac{2h}{\delta_{st}}}, \quad \text{where } h \text{ is height from which the weight is dropped.}$$

Qualifying Exam: Mechanics of Materials

CLOSED BOOK

1. With reference to a rectangular Cartesian coordinate system, the state of strain at a point is given by the matrix

$$[\varepsilon] = \begin{bmatrix} 5 & 3 & 0 \\ 3 & 4 & -1 \\ 0 & -1 & 2 \end{bmatrix} \times 10^{-4}$$

What is the change of the angle between two initially perpendicular lines in the directions of $3\mathbf{e}_1 + 2\mathbf{e}_2 - 2\mathbf{e}_3$ and $2\mathbf{e}_1 + 3\mathbf{e}_3$ emanating from the point?

2. At point P , the matrix of components of stress tensor (with respect to axes x_1, x_2, x_3) is as follows:

$$[\sigma_{ij}] = \begin{bmatrix} 20 & 10 & -10 \\ 10 & 30 & 0 \\ -10 & 0 & 50 \end{bmatrix} MPa$$

Determine:

- The traction vector on a plane passing through this point and parallel to the plane $2x + y - 3z = 12$;
- The normal and shear tractions on the plane;

Qualifying Exam: Mechanics of Materials

CLOSED BOOK

3. A cantilever beam has a Z section of uniform thickness for which

$$I_y = 2th^3/3 \quad \text{and} \quad I_z = 8th^3/3$$

and

$$I_{yz} = -th^3.$$

Determine the maximum bending stress in the beam subjected to a load P at its free end.

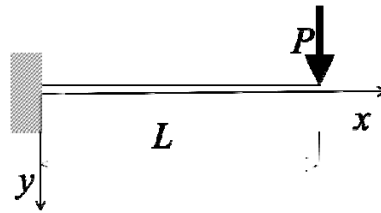

4. Consider two bars, one having a circular section of radius b , the other an elliptical section with semi-axes a and b ($b < a$).

For equal allowable shearing stresses, determine which bar resists a larger torque.

Qualifying Exam: Mechanics of Materials

CLOSED BOOK

1. Two 50×100 mm beams are glued together as shown. What is the required glue strength for both cross-sections?

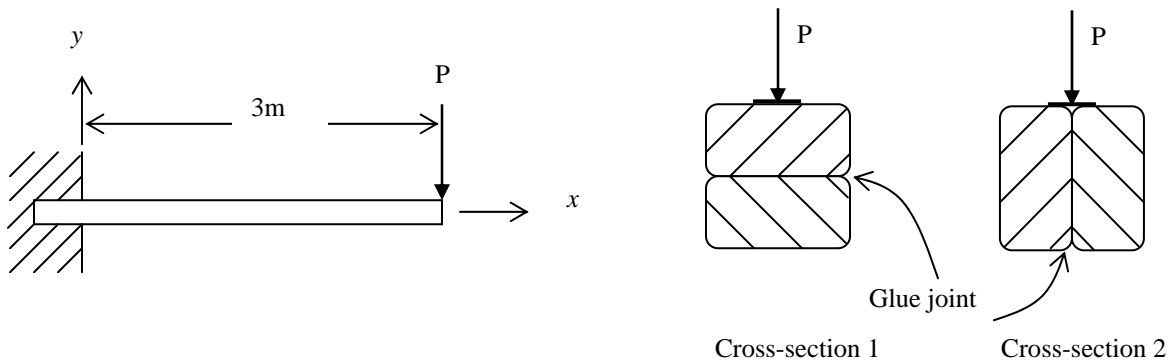

2. For the following matrix of components of stress tensor $\begin{pmatrix} 2 & 0 & 2 \\ 0 & 2 & 4 \\ 2 & 4 & 2 \end{pmatrix} \times 10^8 Pa$ find the traction

vector on the plane shown.

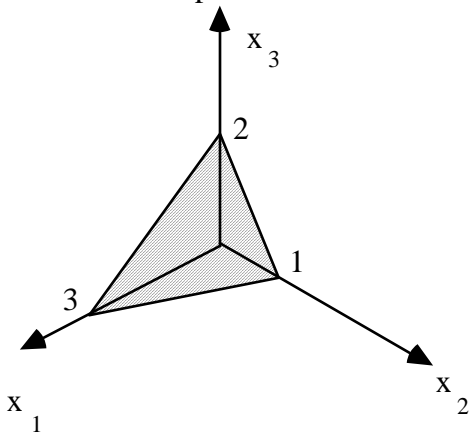

Hint: one of the ways to write down a normal to a plane is to take a vector product of any two vectors belonging to this plane

Qualifying Exam: Mechanics of Materials

CLOSED BOOK

3. With reference to a rectangular Cartesian coordinate system, the state of strain at a point is given by the matrix

$$[\varepsilon] = \begin{bmatrix} 2 & 1 & 0 \\ 1 & 2 & -1 \\ 0 & -1 & 2 \end{bmatrix} \times 10^{-4}$$

What is the change of the angle between two initially perpendicular lines in the directions of $2e_1 + 2e_2 + e_3$ and $2e_1 - 6e_3$ emanating from the point?

4. In a typical application, a standard hex bolt and nut are used to clamp together two plates. As the nut is tightened, a small rectangular strain gage rosette, mounted as shown on the bolt shank, registers strains that are converted into the following stresses (ksi):

$$\sigma_0 = -9, \sigma_{45} = 21, \sigma_{90} = 29$$

From these results, the principal stresses are very nearly:

$$\sigma_1 = 31.5 \text{ and } \sigma_2 = -11.2$$

- On a separate sheet, carefully sketch the Mohr's circle that depicts the two dimensional state of stress at the location of the strain gage rosette. On this Mohr's circle indicate the normal and shearing stresses in the 0, 45, and 90 degree gage directions. Label the axes.
- Estimate the magnitude of the clamping force along the bolt axis, that is, in the 45 degree direction.

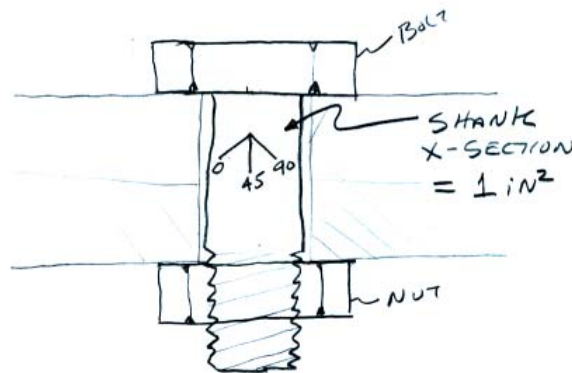

It may be helpful to recall:

Name _____

Summer 2007

Qualifying Exam: Mechanics of Materials

CLOSED BOOK

$$\sigma_1 = \frac{\sigma_x + \sigma_y}{2} + \sqrt{\left(\frac{\sigma_x - \sigma_y}{2}\right)^2 + \tau_{xy}^2}$$

$$\sigma_2 = \frac{\sigma_x + \sigma_y}{2} - \sqrt{\left(\frac{\sigma_x - \sigma_y}{2}\right)^2 + \tau_{xy}^2}$$

Name _____

Fall 2006

Qualifying Exam: Mechanics of Materials

CLOSED BOOK

This portion of the qualifying exam is **closed** book. You may have a calculator.

Work 3 of the 4 problems. Be very clear which 3 you want graded (see below). It is not acceptable to work all 4 problems and hope that the graders pick out the best worked three.

I want problems #___, #___, and #___ graded.

Be sure to put your name on all papers handed in, including this cover sheet.

1. With reference to a rectangular Cartesian coordinate system, the state of strain at a point is given by the matrix

$$[\varepsilon] = \begin{bmatrix} 5 & 3 & 0 \\ 3 & 2 & -1 \\ 0 & -1 & 4 \end{bmatrix} \times 10^{-4}$$

What is the unit elongation in the direction $e_1 + 2e_2 + 2e_3$?

Qualifying Exam: Mechanics of Materials

CLOSED BOOK

2. Using St-Venant's principle, judge which of the three boundary conditions will result in approximately similar stress states somewhat away from the boundary:

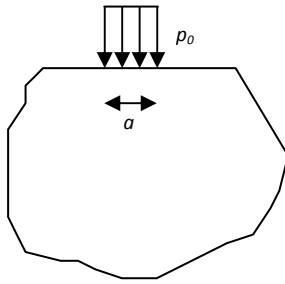

(a)

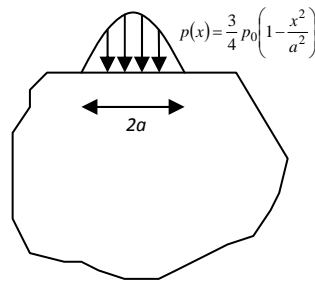

(b)

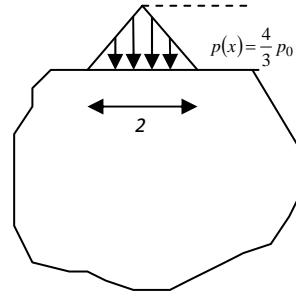

(c)

3. At point P , the matrix of components of stress tensor (with respect to axes x_1, x_2, x_3) is as follows:

$$[\sigma_{ij}] = \begin{bmatrix} 100 & 50 & -100 \\ 50 & 200 & 100 \\ -100 & 100 & -200 \end{bmatrix} MPa$$

Determine traction vector on a plane with unit normal $(\sqrt{3}/3, \sqrt{3}/3, \sqrt{3}/3)$ passing through this point

4. A tensile test is performed on a 12-mm-diameter aluminum alloy specimen ($\nu = 0.33$) using a 50-mm gage length. When an axial tensile load reaches a value of 16 kN, the gage length has increased by 0.10 mm. Determine (a) the Young's modulus; (b) the decrease Δd in diameter and the dilatation of the bar

Name _____

Fall 2005

Qualifying Exam: Mechanics of Materials

CLOSED BOOK

This portion of the qualifying exam is **closed** book. You may have a calculator.

Work 3 of the 4 problems. Be very clear which 3 you want graded (see below). It is not acceptable to work all 4 problems and hope that the graders pick out the best worked three.

I want problems #____, #____, and #____ graded.

Be sure to put your name on all papers handed in, including this cover sheet.

1. At a point in an isotropic elastic body the principal strains ϵ_1 , ϵ_2 , ϵ_3 are in the ratio 3:4:5; the largest principal stress is $\sigma_1 = 140 \text{ MPa}$. Determine the values of principal stresses σ_2 and σ_3 if $\nu = 0.3$, $E = 200 \text{ GPa}$.
2. The inner surface of a hollow cylinder internally pressurized to 100 MPa experiences tangential and axial stresses of 600 and 200 MPa, respectively. Make a Mohr circle representation of the stresses on the inner surface. What maximum shear stress exists at the inner surface?
3. A tensile test is performed on a 12-mm-diameter aluminum alloy specimen ($\nu = 0.33$) using a 50-mm gage length. When an axial tensile load reaches a value of 16 kN, the gage length has increased by 0.10 mm. Determine (a) the Young's modulus; (b) the decrease Δd in diameter and the dilatation of the bar

Qualifying Exam: Mechanics of Materials

CLOSED BOOK

4. Figure shows a plastic beam having a box section, where the top plate is cemented in place. Determine the shear stress acting on the cemented joint for both designs. Is one design better than the other?

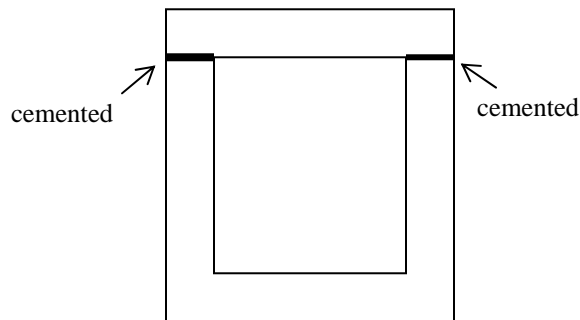
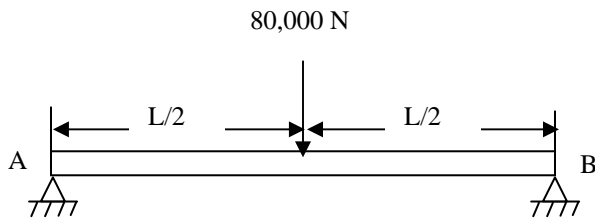

Design "a"

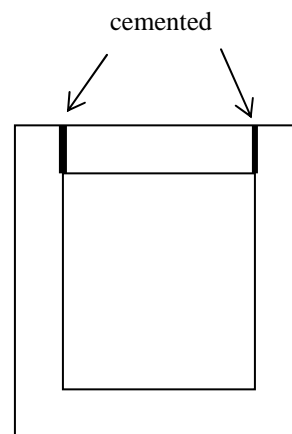

Design "b"

NAME: _____

Fall 2004

Qualifying Examination
Subject: Mechanics of Materials

This portion of the qualifying exam is **closed** book. You may have a calculator.

Work 3 of the 4 problems. Be very clear which 3 you want graded (see below). It is not acceptable to work all 4 problems and hope that the graders pick out the best worked three.

I want problems #____, #____, and #____ graded.

Be sure to put your name on all papers handed in, including this cover sheet.

Problem 1:

A 45° rosette is used to measure strain at a critical point on the surface of a loaded beam. The readings are:

$$\varepsilon_a = -200\mu; \varepsilon_b = 100\mu; \varepsilon_c = 100\mu \text{ for } \theta_a = 0^\circ, \theta_b = 45^\circ, \text{ and } \theta_c = 90^\circ.$$

Calculate the principal stresses and their directions.

Use $E = 200 \text{ GPa}$ and $\nu = 0.3$

Problem 2:

A hollow ($R_{\text{internal}} = b, R_{\text{external}} = c$) and a solid ($R = a$) cylindrical shaft are constructed of the same material. The shafts are of identical length and cross-sectional area and both are subjected to pure torsion. Determine the ratio of the largest torques that may be applied to the shafts for $c = 1.4b$

- (a) if the allowable stress is τ_a
- (b) if the allowable angle of twist is θ_a .

Problem 3:

At point P , the matrix of components of the stress tensor (with respect to axes x_1, x_2, x_3) is as follows:

$$[\sigma_{ij}] = \begin{bmatrix} 100 & 100 & -100 \\ 100 & 200 & 0 \\ -100 & 0 & -350 \end{bmatrix}$$

Determine:

- (a) the traction vector on a plane passing through this point with unit normal $(-2/3, \sqrt{3}/3, \sqrt{2}/3)$
and
- (b) the normal and shear tractions on the plane.

Problem 4:

Consider a beam of rectangular cross-section ($h \times b$) and length L . The beam is loaded by force T at the free end. Find the maximal normal stress σ_n and shear τ_n tractions along the glue connection and the point(s) where they occur.

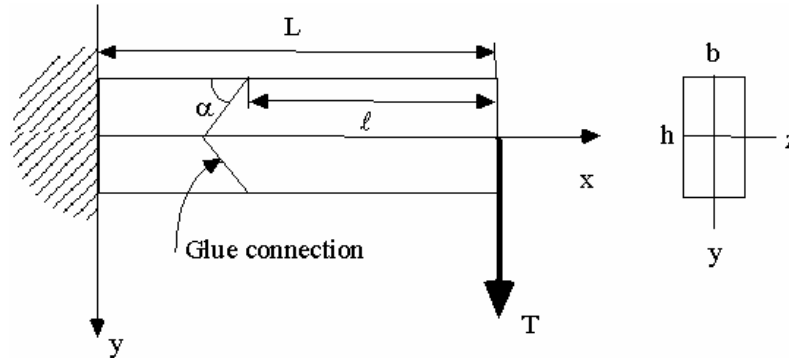

$$L = 10, \quad l = 5, \quad h = 1, \quad b = 1/2, \quad \alpha = 45^\circ$$

Supplementary formulas:

The stresses at point (x_0, y_0) of the beam of rectangular cross-section ($h \times b$) and length L loaded by force T at the free end are as follows:

$$\sigma_{xx} = -\frac{M(x_0)y_0}{I_z}, \quad \sigma_{xy} = \frac{T}{I_z b} S_z(y_0)$$

where

$$I_z = \frac{bh^3}{12} \text{ - cross-sectional moment of inertia}$$

$$M(x_0) = T(L - x_0) \text{ - bending moment at the cross-section with coordinate } x_0$$

$$S_z(y_0) = \frac{b}{2} \left(\frac{h^2}{4} - y_0^2 \right)$$

NAME: _____

Fall 2003

Qualifying Examination
Subject: Mechanics of Materials

This portion of the qualifying exam is **closed** book. You may have a calculator.

Work 3 of the 4 problems. Be very clear which 3 you want graded (see below). It is not acceptable to work all 4 problems and hope that the graders pick out the best worked three.

I want problems #____, #____, and #____ graded.

Be sure to put your name on all papers handed in, including this cover sheet.

Problem 1:

Determine the deflection at any point in the beam. Use singularity functions.

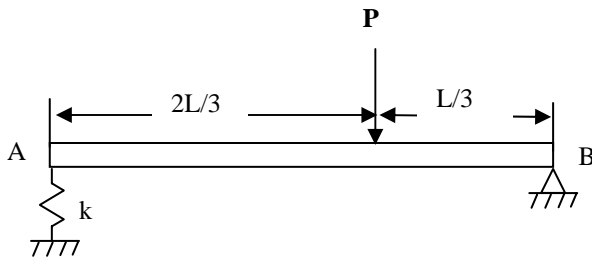

Problem 2:

A rectangular plate is under a uniform state of plane stress in xy plane. It is known that the maximum tensile stress acting on any face (whose normal lies in the xy plane) is 75 MN/m^2 . It is also known that on a face perpendicular to the x axis there is acting a compressive stress of 15 MN/m^2 and no shear stress. No explicit information is available as to the values of the normal stress σ_y , and τ_{xy} acting on the face perpendicular to the y axis.

Find the stress components acting on the faces perpendicular to the a and b axes which are located as shown in the sketch.

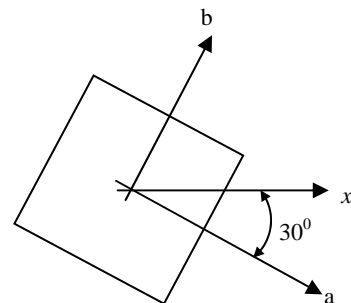
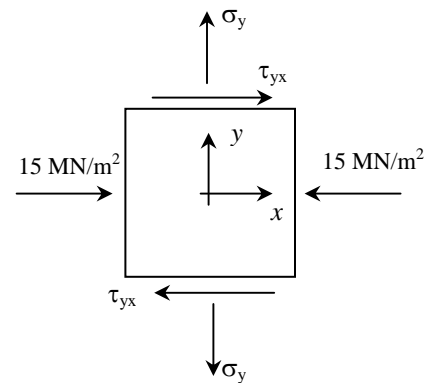

NAME: _____

Fall 2003

Problem 3:

A steel bar ($E = 207 \text{ GPa}$) of 6 cm^2 cross-section and 6 m length is acted on by the indicated axially applied forces. Find the total elongation of the bar

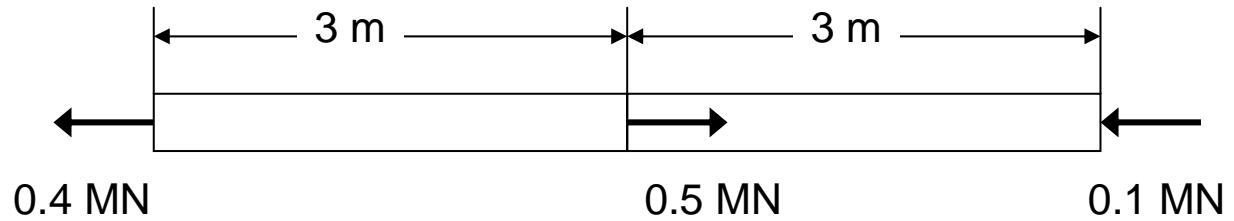

Problem 4:

A 45° strain rosette is used to measure strain at critical point on the surface of a loaded beam. The readings are:

$$\varepsilon_a = -100\mu, \varepsilon_b = 50\mu, \varepsilon_c = 100\mu$$

for

$$\theta_a = 0^\circ, \theta_b = 45^\circ, \theta_c = 90^\circ$$

Calculate the principal stresses and maximum in-plane shearing stress if $E = 200 \text{ GPa}$, $\nu = 0.3$.

Qualifying Exam Summer 2003

Mechanics of Materials

This portion of the qualifying exam is closed book. Work all problems.

Problem 1:

Strain rosette readings are made at a critical point on the free surface in a structural steel member. The 60° rosette contains three wire gages positioned at $\theta_a = 0^\circ$, $\theta_b = 60^\circ$, and $\theta_c = 120^\circ$. The readings are $\varepsilon_a = 190\mu$; $\varepsilon_b = 200\mu$; $\varepsilon_c = -300\mu$. Determine (a) the in-plane principal strains and stresses and their directions, (b) the true maximum shearing strain. The material properties are $E = 200 \text{ GPa}$ and $\nu = 0.3$.

Problem 2:

A right-angled-cantilevered bracket with concentrated load and torsional loading at the free end is shown in the figure. Using Castigliano's theorem, find the deflection at the free end in the z direction. Neglect transverse shear effects.

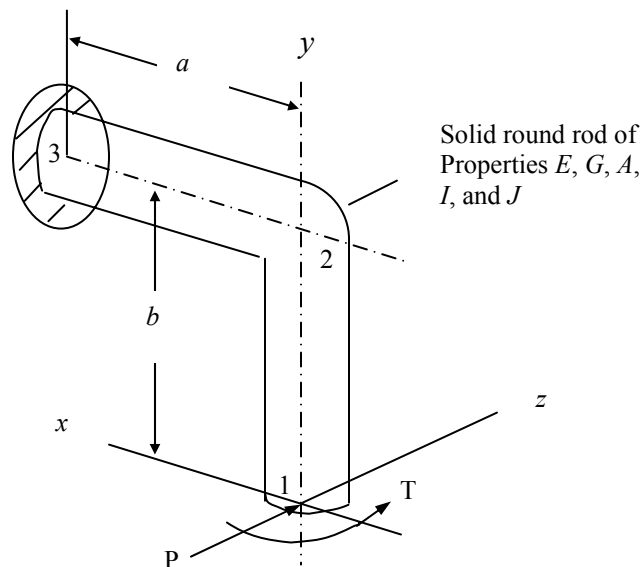

Problem 3:

Given the following stress field within a structural member,

$$\sigma_x = a[y^2 + b(x^2 - y^2)] \qquad \tau_{xy} = -2abxy$$

$$\sigma_y = a[x^2 + b(y^2 - x^2)] \qquad \tau_{xz} = \tau_{yz} = 0$$

$$\sigma_z = ab(y^2 + x^2)$$

where a and b are constants. Determine, whether this stress distribution represents a solution for a plane strain problem. The body forces are omitted.

Problem 4:

An aluminum rod $\frac{3}{4}$ in. in diameter and 48 in. long and a nickel steel rod $\frac{1}{2}$ in. in diameter and 32 in. long are spaced 60 in. apart and fastened to a horizontal beam that carries a 2000 lbf load, as shown in the figure. The beam is to remain horizontal after load is applied. Assume that the beam is weightless and absolutely rigid. Find the location x of the load and determine the stresses in each rod. (Young's modulus: $E_{\text{steel}} = 30 \times 10^6$ lbf/in² and $E_{\text{al}} = 10.3 \times 10^6$ lbf/in²).

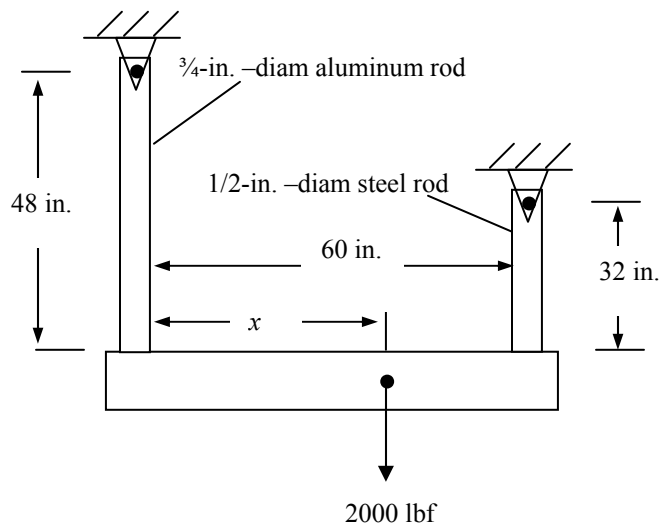

Qualifying Exam Spring 2003 Mechanics of Materials

This portion of the qualifying exam is closed book. Work all problems.

Problem 1:

A 45° rosette is used to measure strain at a critical point on the surface of a loaded beam. The readings are: $\varepsilon_a = -100\mu$; $\varepsilon_b = 50\mu$; $\varepsilon_c = 100\mu$, for $\theta_a = 0^\circ$; $\theta_b = 45^\circ$; and $\theta_c = 90^\circ$. Calculate the principal stresses and their directions. Use $E = 200 \text{ GPa}$ and $\nu = 0.3$.

Problem 2:

Determine deflection $y(x)$ as a function of x using singularity functions. Neglect the weight of the bar.

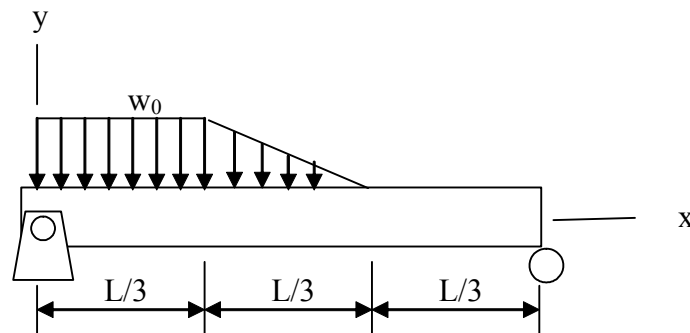

Problem 3:

An aluminum core having a diameter d_i of 30 mm is placed within a tubular steel shaft having a diameter d_o of 50 mm. A flange is welded to the end of the shaft, and an axial force of 100 kN is applied. The shaft is 100 mm long. Find the deflection at the end of the shaft and the stresses induced in the aluminum and steel sections of the shaft. Assume that the moduli of elasticity are $2 \times 10^{11} \text{ Pa}$ for steel and $0.7 \times 10^{11} \text{ Pa}$ for aluminum.

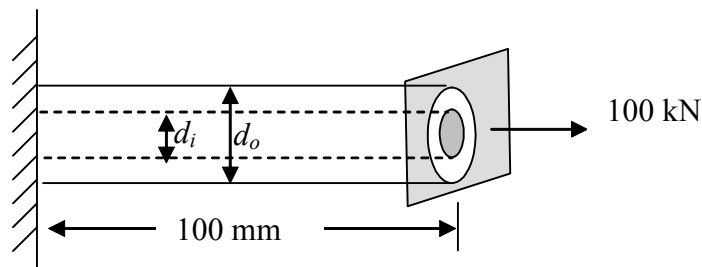

Problem 4:

Given the state of stress (in MPa) shown in the sketch. Determine the principal stresses and their directions and maximal shear stress.

